

4	5	6
PART NUMBER	BODY MATERIAL	FILTER MATERIAL
E-M-160037	POLYPROPYLENE	STAINLESS STEEL
E-M-160038	POLYPROPYLENE	STAINLESS STEEL
		FILTER(μ)
		149 MICRON
		74 MICRON

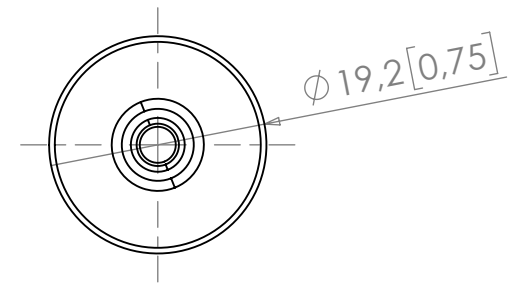
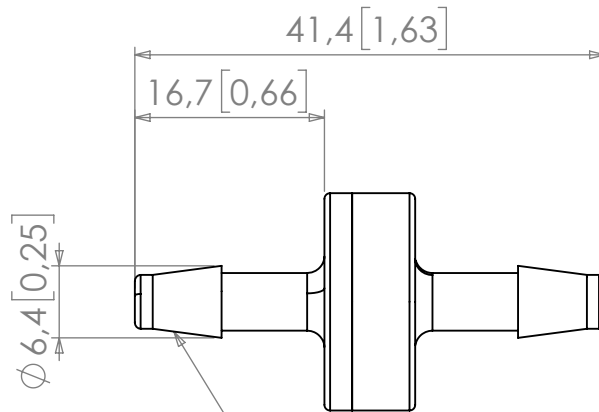

TO SUIT 4.8MM (3/16") ID TUBE

1	WTsang	TTsang	SBurton	29/07/2016		
REV	CREATED	CHECKED	APPROVED	REV DATE	REF No.	REVISION SUMMARY

MATERIAL: POLYPROPYLENE, 304 STAINLESS STEEL

If dimensional information is critical, please contact Eoxshop.com for confirmation. All dimensions are in accordance with the manufacturers drawings and are subject to change without prior notice.

EOXSHOP
 TEL: +44 (0) 23 9226 6031
 WWW.EOXSHOP.COM
 SALES@EOXSHOP.COM



TITLE: MINIATURE IN-LINE FILTER, 74 MICRON, BARBS TO SUIT 3/16" ID TUBING

	DIM'S mm[inch]	SCALE NTS	SIZE A4	SHEET 1 / 1	DOCUMENT NUMBER E-M-160038	REVISION 1
--	-------------------	--------------	------------	----------------	-------------------------------	---------------